

AB1

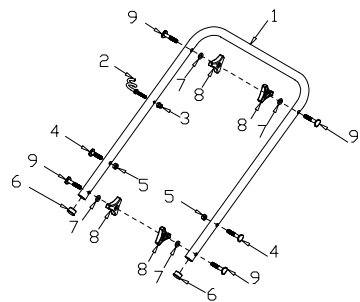

AA1

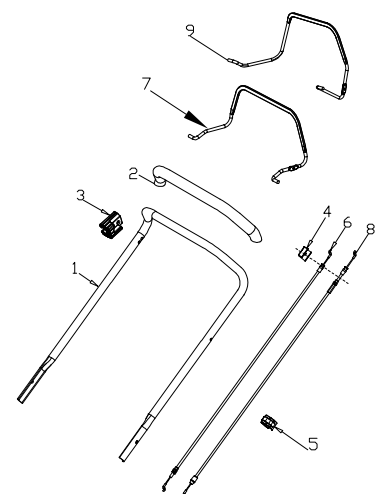

B

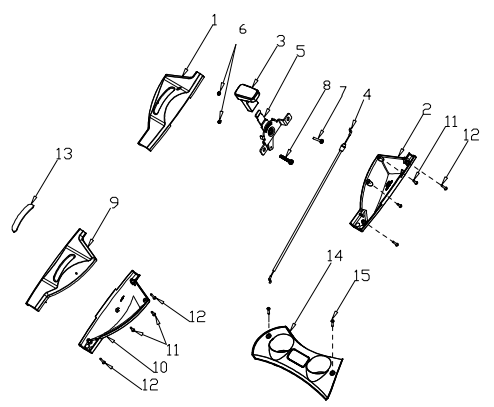

C

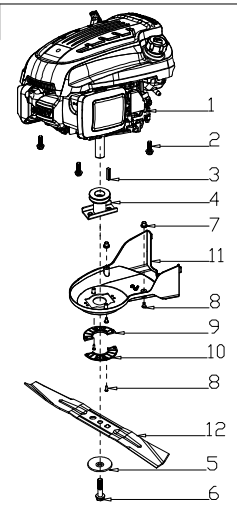

D

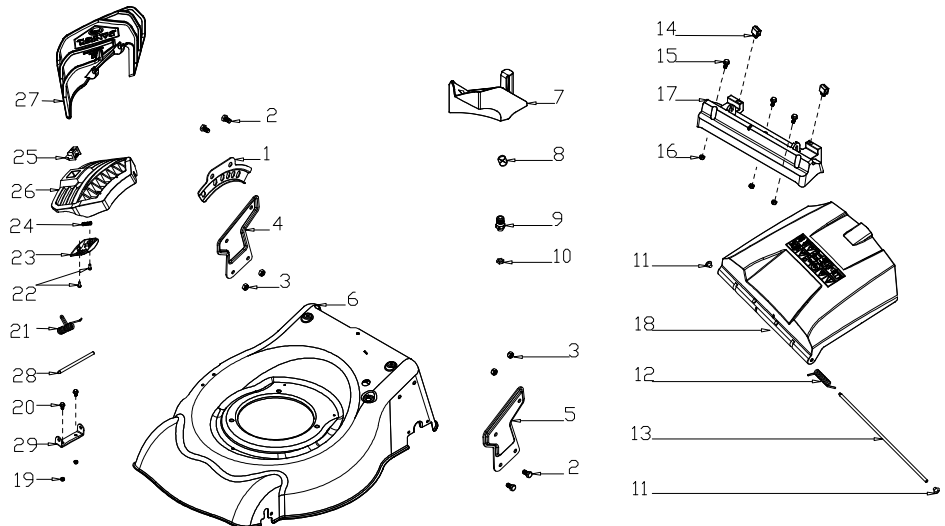

E

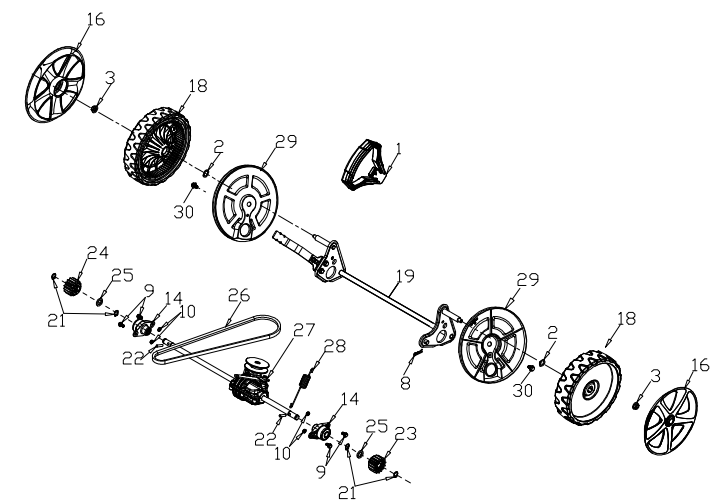

F

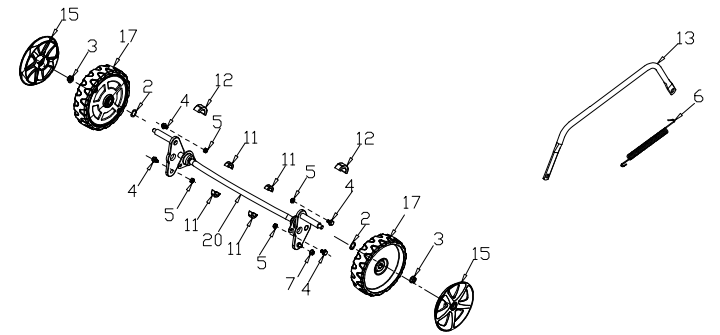
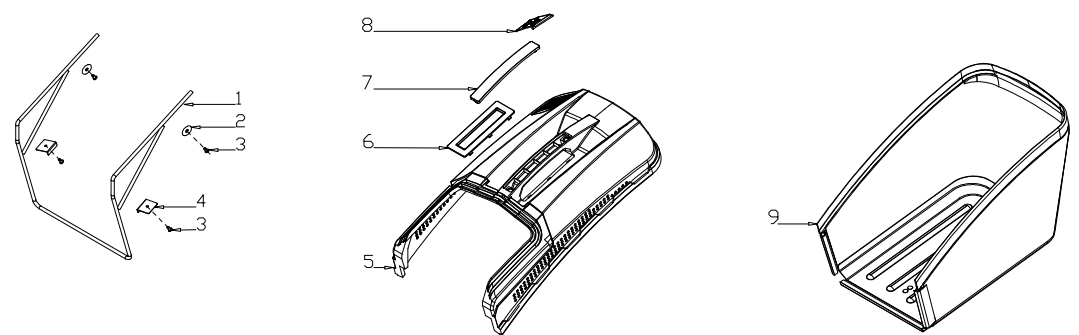

No.	Part name	Qty
AA1-1	Upper Handle	1
AA1-2	Foam Pipe	1
AA1-3	Limiting Stopper	1
AA1-4	Cable Fixing Clamp	1
AA1-5	Cable Support	1
AA1-6	Cable	1
AA1-7	Brake Lever	1
AA1-8	Clutch cabel	1
AA1-9	Clutch Lever	1
AB1-1	Lower Handle	1
AB1-2	Rope Guide	1
AB1-3	Nut	1
AB1-4	Bolt	2
AB1-5	Nut	2
AB1-6	Handle Plug	2
AB1-7	Flat Washer	4
AB1-8	Knob	4
AB1-9	Bolt	4
B-1	Upper Cover of Left Panel	1
B-2	Lower Cover of Left Panel	1
B-3	Plastic Grip	1
B-4	Cable	1
B-5	Handle	1
B-6	Nut	2
B-7	Bolt	1
B-8	Bolt	1
B-9	Upper Cover of Right Panel	1
B-10	Lower Cover of Right Panel	1
B-11	Screw	4
B-12	Screw	4
B-13	Handle Panel	1
B-14	Handle Panel	1
B-15	Screw	2
C-1	Engine	1
C-2	Bolt	3
C-3	Flat Key	1
C-4	Blade adapter	1
C-5	Blade Washer	1
C-6	Blade Bolt	1
C-7	Screw Cap	2
C-8	Screw	4
C-9	Belt Cover Plate	1
C-10	Belt Cover Plate	1
C-11	Belt Cover	1
C-12	20" Blade	1
C-13	Engine Cover	1
C-14	Screw	3
C-15	Filtering Net Duct of Fuel	1
C-16	Oil Pipe Circlip I	1
D-1	Height Adjustment Plate	1
D-2	Bolt	4
D-3	Nut	4
D-4	Right Bracket	1
D-5	Left Bracket	1
D-6	Deck	1

D-7	Mulching Plug	1
D-8	Cable Sleeve	1
D-9	Washing Linker	1
D-10	Nut	1
D-11	plug	2
D-12	Rear Cover Spring	1
D-13	Rear Cover Shaft	1
D-14	Rear Cover Support	2
D-15	Bolt	3
D-16	Nut	3
D-17	Rear Cover Pedestal	1
D-18	Rear Cover	1
D-19	Nut	2
D-20	Bolt	2
D-21	Side Discharge Cover Spring	1
D-22	Screw	2
D-23	Cover Plate	1
D-24	Spring	1
D-25	Lock	1
D-26	Side Discharge Cover	1
D-27	Side-Discharge Guiding Board	1
D-28	Side Discharge Cover Shaft	1
D-29	Side Discharge Bracket	1
E-1	Height Adjustment Handle	1
E-2	Spring Washer	4
E-3	Nut	4
E-4	Bolt	4
E-5	Nut	4
E-6	Height adjustment Spring	1
E-7	Nut	1
E-8	Split Pin	1
E-9	Bolt	4
E-10	Nut	4
E-11	Shaft Sleeve	4
E-12	Bush	2
E-13	Height Adjustment Connecting Rod	1
E-14	Shaft Sleeve	2
E-15	8" Outer Wheel Cover	2
E-16	11" Outer Wheel Cover	2
E-17	8" Wheel	2
E-18	11" wheel	2
E-19	Rear Wheel Shaft	1
E-20	Front Wheel Shaft	1
E-21	Lock Ring	4
E-22	Pin	2
E-23	Left Gear	1
E-24	Right Gear	1
E-25	Flat Washer	2
E-26	Belt	1
E-27	Gearbox	1
E-28	Spring	1
E-29	Inner Wheel Cover	2
E-30	Bolt	2
F-1	Metal Bracket	1
F-2	Flat Washer	2
F-3	Screw	4

F-4	fixed plate	2
F-5	Plastic Cover	1
F-6	Cover Plate	1
F-7	Handle cover	1
F-8	Indicated Board	1
F-9	Fabric bag	1