

AB1

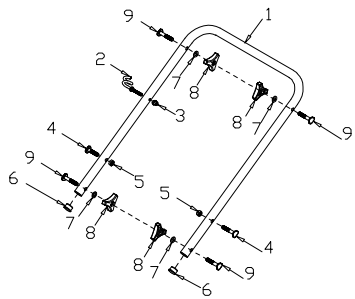

AA1

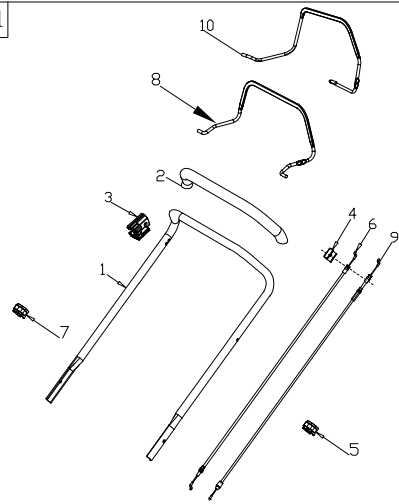

B

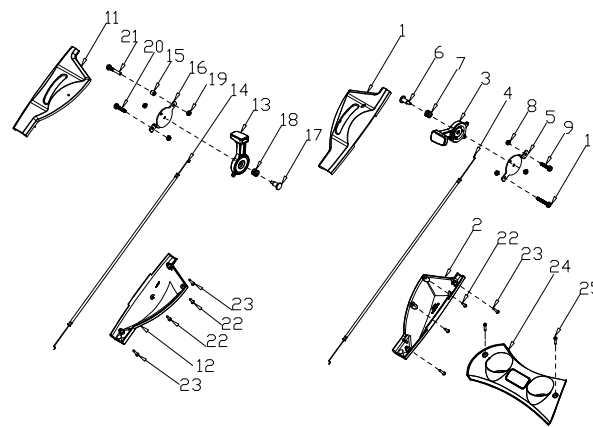

C

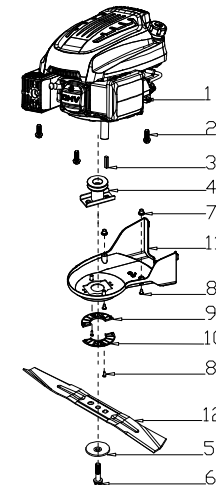

D

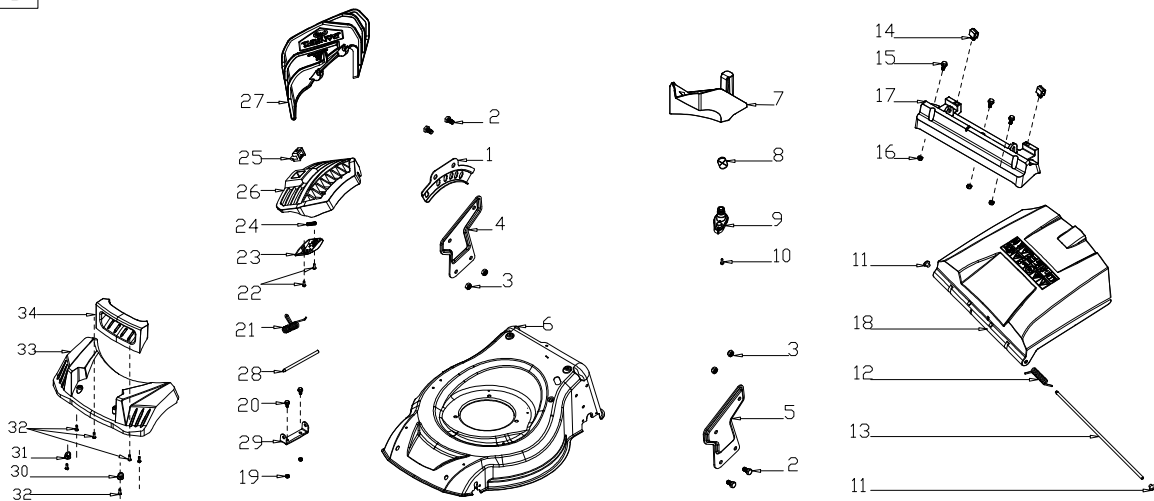

E

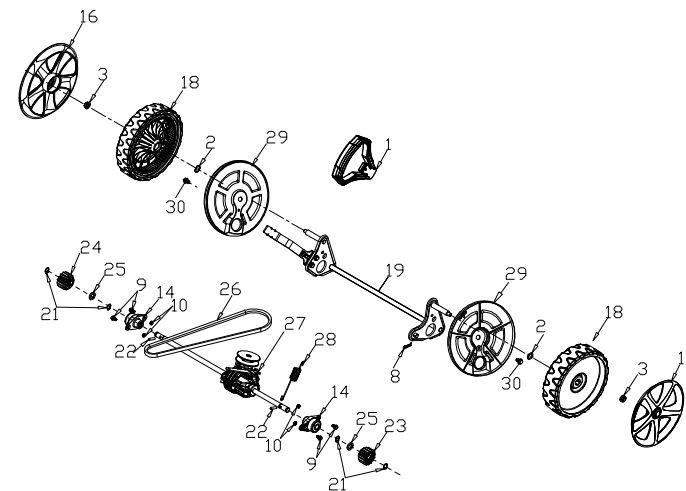

F

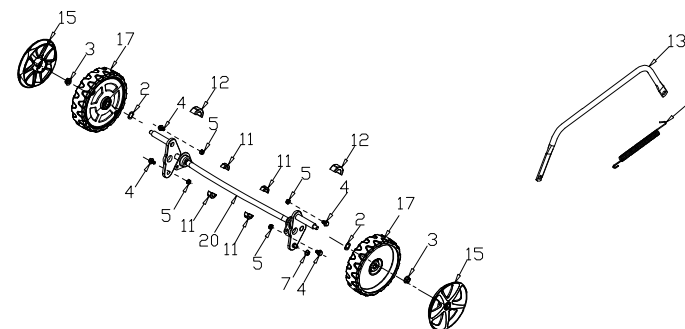
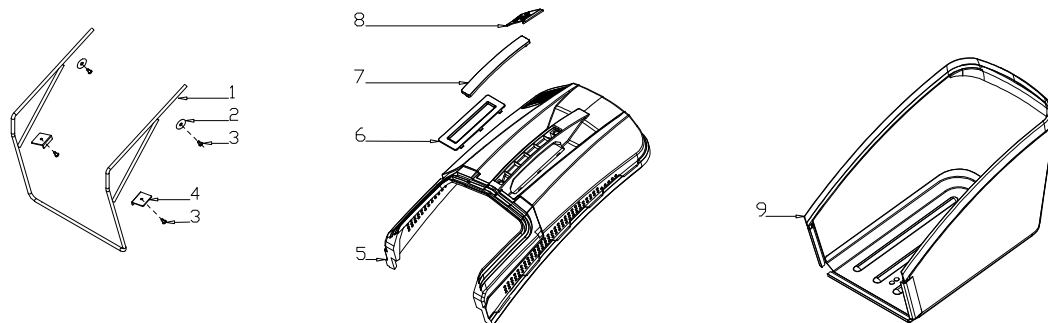

No.	Part name
AA1-1	Upper Handle
AA1-2	Foam Pipe
AA1-3	Limiting Stopper
AA1-4	Cable Fixing Clamp
AA1-5	Cable Support
AA1-6	Brake Cable
AA1-7	Cable Support
AA1-8	Brake Lever
AA1-9	Clutch cabel
AA1-10	Clutch Lever
AB1-1	Lower Handle
AB1-2	Rope Guide
AB1-3	Nut
AB1-4	Bolt
AB1-5	Nut
AB1-6	Handle Plug
AB1-7	Flat Washer
AB1-8	Knob
AB1-9	Bolt
B-1	Upper Cover of Left Panel
B-2	Lower Cover of Left Panel
B-3	Handle
B-4	Cable
B-5	Bolt
B-6	Screw
B-7	Spring
B-8	Nut
B-9	Bolt
B-10	Bolt
B-11	Upper Cover of Right Panel
B-12	Lower Cover of Right Panel
B-13	Handle
B-14	Cable
B-15	Bush
B-16	Bolt
B-17	Screw
B-18	Spring
B-19	Nut
B-20	Bolt
B-21	Bolt
B-22	Screw
B-23	Screw
B-24	Handle Panel
B-25	Screw
C-1	Engine
C-2	Bolt

C-3	Flat Key
C-4	Blade adapter
C-5	Blade Washer
C-6	Blade Bolt
C-7	Screw Cap
C-8	Screw
C-9	Belt Cover Plate
C-10	Belt Cover Plate
C-11	Belt Cover
C-12	21" Blade
C-13	Engine cover
C-14	Screw
C-15	Filtering Net Duct of Fuel
C-16	Oil Pipe Circlip I
D-1	Height Adjustment Plate
D-2	Bolt
D-3	Nut
D-4	Right Bracket
D-5	Left Bracket
D-6	Deck
D-7	Mulching Plug
D-8	Cable Sleeve
D-9	Washing Linker
D-10	Screw
D-11	plug
D-12	Rear Cover Spring
D-13	Rear Cover Shaft
D-14	Rear Cover Support
D-15	Bolt
D-16	Nut
D-17	Rear Cover Pedestal
D-18	Rear Cover
D-19	Nut
D-20	Bolt
D-21	Side Discharge Cover Spring
D-22	Screw
D-23	Cover Plate
D-24	Spring
D-25	Lock
D-26	Side Discharge cover
D-27	Side-Discharge Guiding Board
D-28	Side Discharge Cover Shaft
D-29	Side Discharge Bracket
D-30	Washer L
D-31	Washer R
D-32	Screw
D-33	Front Plastic Face

D-34	Front Plastic Face Handle
E-1	Height Adjustment Handle
E-2	Spring Washer
E-3	Nut
E-4	Bolt
E-5	Nut
E-6	Height adjustment Spring
E-7	Nut
E-8	Split Pin
E-9	Bolt
E-10	Nut
E-11	Shaft Sleeve
E-12	Bush
E-13	Height Adjustment Connecting Rod
E-14	Shaft Sleeve
E-15	8" Outer Wheel Cover
E-16	11" Outer Wheel Cover
E-17	8" Wheel
E-18	11" wheel
E-19	Rear Wheel Shaft
E-20	Front Wheel Shaft
E-21	Lock Ring
E-22	Pin
E-23	Left Gear
E-24	Right Gear
E-25	Flat Washer
E-26	Belt
E-27	Gearbox
E-28	Spring
E-29	Inner Wheel Cover
E-30	Bolt
F-1	Metal Bracket
F-2	Flat Washer
F-3	Screw
F-4	fixed plate
F-5	Plastic Cover
F-6	Cover Plate
F-7	Handle cover
F-8	Indicated Board
F-9	Fabric bag